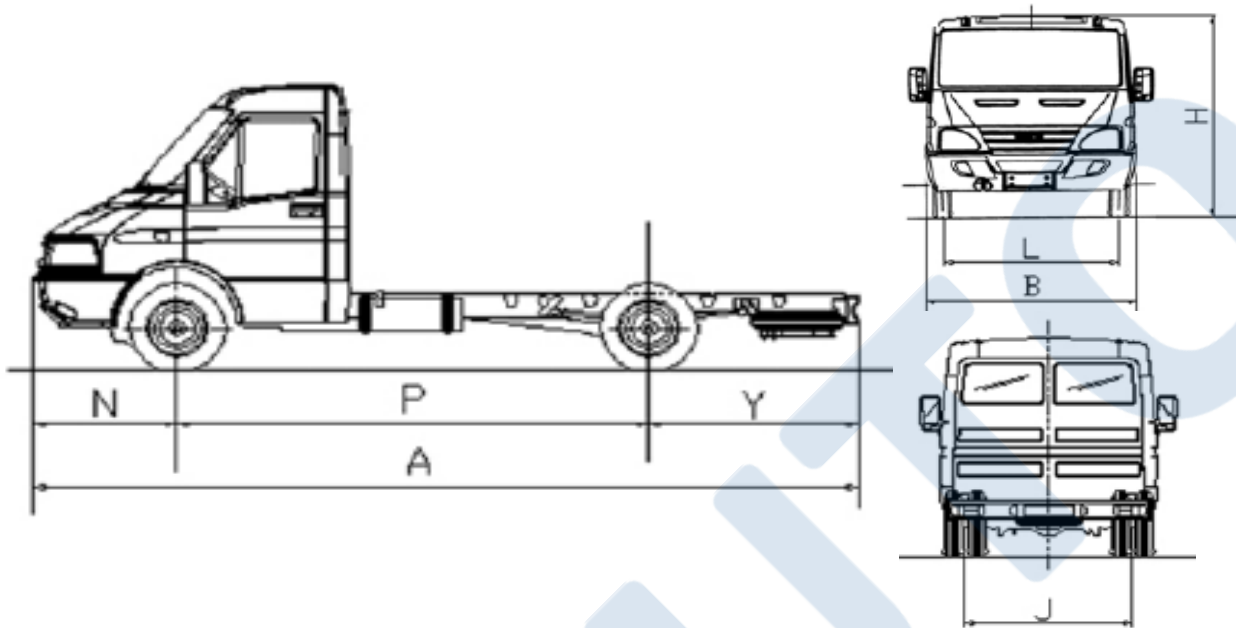

**IVECO**

# 50.13 Chassis Cab

Twin Rear Wheels

*Power Daily***DIMENSIONS (mm)**

P	Wheel base	3600	3950
A	Maximum Length	6425	6800
B	Max Cab width		2000
H	Overall Height (Unladen)		2250
L	Front Track		1695
J	Rear Track		1540
	Front/Rear Ground Clearance		255/220
N	Front Overhang		1000
Y	Rear Overhang	1825	1850
<b>Fix Body Dimensions (OPTIONAL)</b>			
A	Maximum Length (1)	6485	6900
B	Max Cab width (1)		2020
H	Overall Height (Unladen) (1)		2325
Y	Rear Overhang (1)	1885	1950
	Body Length (Internal)	4100	4500
	Maximum Body Width (Internal)		1940
	Side height		400

**Weights (Kg) \***

GVW		5000
Front Axle Capacity		1800
Rear Axle Capacity		3700
Kerb Weight Front Axle (withouth body)	1460	1465
Kerb Weight Rear Axle (withouth body)	675	685
Kerb Weight Total (withouth body)	2135	2150
Max Body and Payload Capacity	2865	2850

(1) Dimensions with fix standard cargo box factory fitted

\* Weights for chassis cab are with full fuel, oils, water and include driver.

The information in this literature is intended to be of general nature only. Iveco reserves the right to modify or change specifications at any time. For more detailed information refer to your dealer.

# 50.13 Chassis Cab

## ENGINE

Type 8140.43S- 4 stroke diesel , 4 Cyl in-line - Turbocharger with Inter-cooler.  
EDC Common Rail Injection system .  
Cast-iron engine block with integral cylinder liners. 2 Valves for Cylinder.  
Water-cooled with electromagnetic fan. Heated fuel filter .  
Oversized radiator. Dry air filter . Emission according **Euro 3** .

### Basic data

Number of Cylinders	4 Vertical In Line
Bore x Stroke	94,4 mm x 100 mm
Total Displacement	2798 cm3
Maximum Output	127 hp (93kW) at 3600 rpm
Maximum Torque	285 Nm at 1800 rpm

Exhaust pipe with stub-pipe outlet placed at center of cross members.

## TRANSMISSION

Five speeds ,synchromeshed manual transmission.Bowden cable control.  
Gears shifting Lever on Dashboard .

Performance rating (calculated value with standard tyres and axle ratio):

Gear	Gear Ratio	Maximum Geared Speed (Km/h)	Gradeability at GVW (%)
1°:	4,994	--	35
5°:	0,778	115	--

## CLUTCH

Single dry plate , Mechanical.  
External Diameter: 267 mm (10 1/2" ) .

## FRAME

Straight "C" Section steel longitudinal side members with tapered ends and tubular cross members

Wheel base	3600/3950
Side Member Height	174
Side Member Width	66
Side Member Thickness	4

## STEERING

L.H.D., power assisted , rack and pinion type.

## FRONT AXLE

Independent wheels.

## REAR AXLE

Full floating, bevel and crown ,single reduction .

Axle Ratio Standard : 4,889

## SUSPENSION

### Front

Independent with torsion bar.  
(Anti-roll bar is Standard).

### Rear

Semi-elliptic leaf springs and rubber rebound bumpers.  
( Anti-roll bar is Optional ).

## Shock Absorbers

Front and rear heavy duty hydraulic telescopic shock absorbers.

## ELECTRICAL SYSTEM

Battery: 12V - 110 Ah  
Alternator :14V - 120A  
Starter motor output: 2.5 kW.

## BRAKING SYSTEM

Front and Rear DISC

Brake Dim. (mm)	Front	Rear
Disc Diameter.	290	290

## Service and Emergency

Vacuum assisted hydraulic brakes.  
Front an Rear circuit independent , 2 circuit.  
Emergency brake integrated into service brake system.  
Brake failure tell-tale on dashboard.

## Parking Brake

Mechanical , manual brake operating on rear wheels.

## WHEELS / TYRES

Tyres:(6+1) 6,50 R 16C  
Wheels: 5 JK - 16H

## CAB

Semiadvanced cab , monocoque in pressed steel with cataphoresis treatment.  
Roof made of metal sheets.  
Front bumper in plastic material .  
One-piece reinforced safety glass windshield.  
No.2 front hinged doors with access step and electric sliding glass.  
Fixed rear cab windows.

Unified key : doors lock + starter .

Body and boxed members treated with cataphoresis.

Sound-proofing and lagging for cab.

Two external plus one internal viewmirrors.

Two internal sunvisors.

## Driver's and passenger's seats

Washable Fabric lining, with side strip in imitation leather.

Driver: complete with headrest - adjustable in height , sliding seat ; reclining seat back .

Passengers:

Two seats passenger - bench type  
Standard Safety Belts all seats .

## Climate controls.

Heating through hot water exchanger.

Four speed electric fan with five different air distribution modes and cabin air re-circulation.

Windshield and side window defroster and defogger through side/front one position air vents.

Fresh air ventilation obtained through turning off heating unit.

## Standard Air Conditioner

Capacity 5000 Kcal/h with command on dashboard.

## In cab equipment:

Non-reflecting dashboard complete with all main instrumentation with all functions monitored using international symbols .

Main instruments :

- Electronic Tachometer – RPM counter
- Fuel level gauge with reserve indicator
- Engine cooling temperature indicator
- Digital clock
- Odometer with trip indicator

Telltals for all main vehicle function with international simbols.

Cigarette lighter and ashtray

## OTHER EQUIPMENT

Extractable spare wheel, holder ( under rear overhang). 93 litre fuel tank.

Front recovery eye. Emergency triangle.

Front /Rear mudflaps .

Radio (with CD) + loudspeakers

Oil sump repair .

Fire extinguisher .